

Cliff Electronic Components Ltd.

76 Holmethorpe Avenue, Holmethorpe Industrial Estate,
Redhill, Surrey, RH1 2PF, England, UK

Tel: 01737-771375 Fax: 01737-766012 Website: www.cliffuk.co.uk

FIBER OPTIC DATA LINK

DATA SHEET

MODEL NO. : FCR684204R

DATE : 2021-12-03

VERSION : 2.0

DEVICE NO. : ORJ-4 (OPTICAL RECEIVER JACK)

CUSTOMER	DESIGNER	CHECKER	APPROVER

Cliff Electronic Components Ltd.

76 Holmethorpe Avenue, Holmethorpe Industrial Estate,

Redhill, Surrey, RH1 2PF, England, UK

Tel: 01737-771375 Fax: 01737-766012 Website: www.cliffuk.co.uk

Features

- High PD sensitivity for red light
- High speed up to 16 Mbps
- Low power consumption and current dissipation
- +3~+5V power source

Descriptions

The light receiving unit is a standard-package product with connector and opto-electric component packaged with PD and I/V amplifier IC. The function of unit changes the light signal into electric signal.

The unit is operated at +3~+5V and the input signal is TTL compatible. FCR684204R has a maximum operating speed of 16 Mbps.

Applications

- PC, Notebook
- MD
- Amplifier
- Audio equipment
- Digital optical data link
- Sound Card

Device Selection Guide

Chip		Operating Voltage (Vcc)	Dissipation Current(mA)	Fiber Coupling Light Output (dBm)		
IC Material	PD λ p(nm)			Typ.	Min.	Typ.
Si	660	+3~+5V	2.5	-24	-	-14.5

Cliff Electronic Components Ltd.

76 Holmethorpe Avenue, Holmethorpe Industrial Estate,
Redhill, Surrey, RH1 2PF, England, UK

Tel: 01737-771375 Fax: 01737-766012 Website: www.cliffuk.co.uk

Package Dimensions

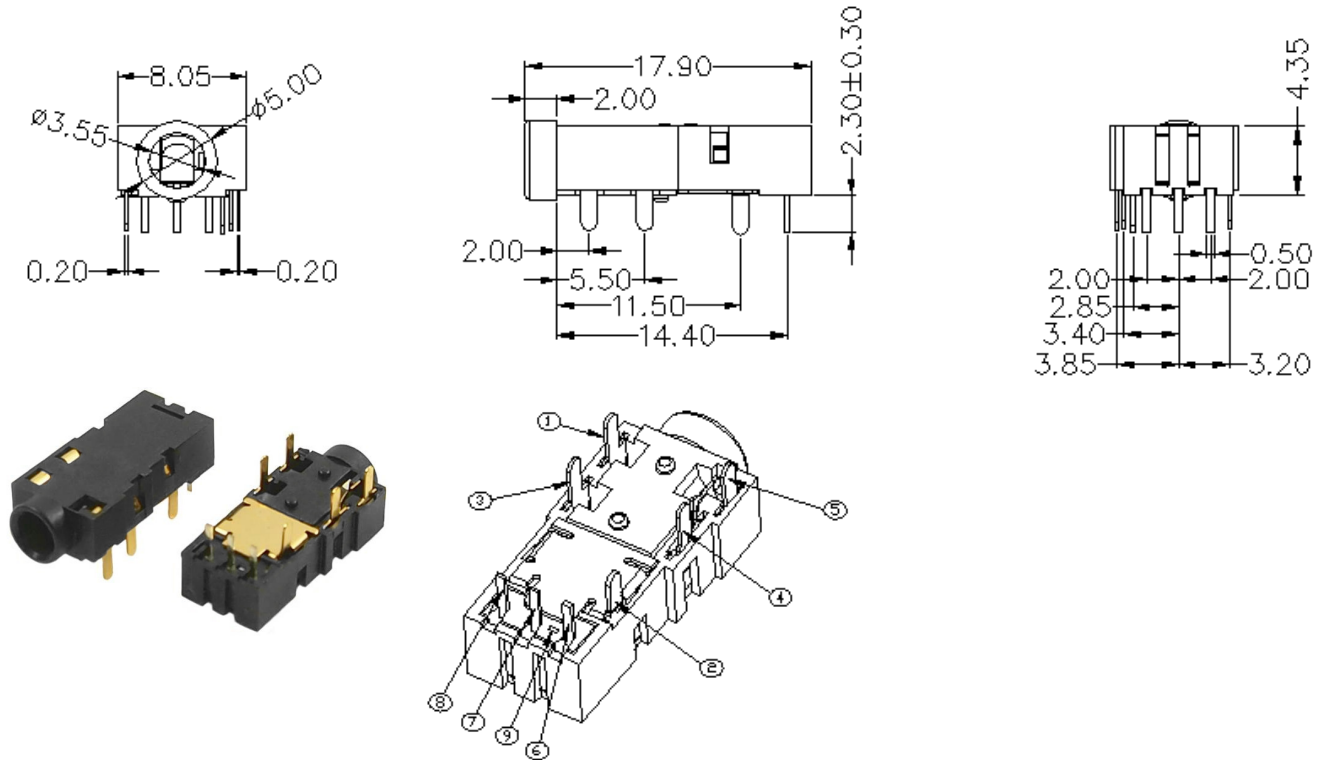

Notes: 1. All dimensions are in millimeters.

2. General Tolerance: ± 0.2 mm

3. Pin 1 ~ 5 golden plating.

Pin Function

1 ~ 5 : jack terminal (1,5 : detector ; 4 : GND ; 2 : left channel ; 3 : right channel)

6 ~ 9 : device terminal (6 : Vout ; 7 : GND ; 8 : Vcc 9 : internal connection)

Cliff Electronic Components Ltd.

76 Holmethorpe Avenue, Holmethorpe Industrial Estate,
Redhill, Surrey, RH1 2PF, England, UK

Tel: 01737-771375 Fax: 01737-766012 Website: www.cliffuk.co.uk

Jack Terminal Configuration

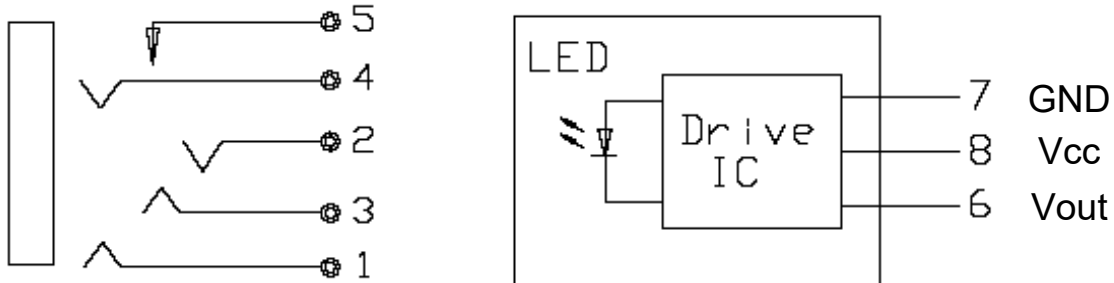

Optical circular plug (satisfies EIAJ RC-5720B)

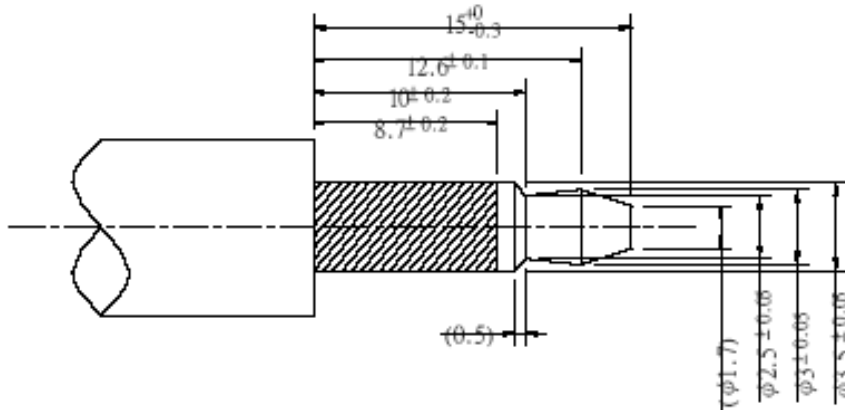

3-pole small-sized concentric plug (satisfy JIS C 6560)

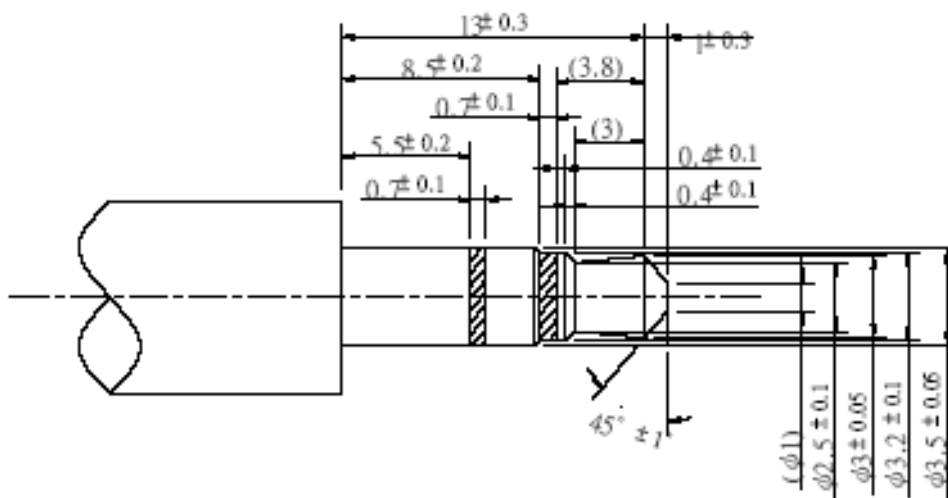

Cliff Electronic Components Ltd.

76 Holmethorpe Avenue, Holmethorpe Industrial Estate,
Redhill, Surrey, RH1 2PF, England, UK

Tel: 01737-771375 Fax: 01737-766012 Website: www.cliffuk.co.uk

Optical Mini-jack Connection

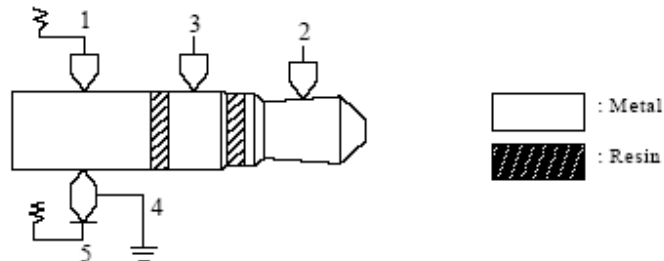

Analog electric signal



Digital optical signal



Input side	Output side
LINE IN MIC	LINE OUT HEAD PHONE
Optical digital input	Optical digital output

Type of plug	Output of terminal		Output of terminal
	5	1	2,3
Analog electricity	L	L	Signal data input/output
Digital optics	L	H	Signal data output
No plug	H	H	-

Absolute Maximum Ratings(Ta = 25°C)

Parameter	Symbol	Rating	Unit
Supply Voltage	Vcc	0~5.5	V
Storage Temperature	Tstg	-30 to 80	°C
Operating Temperature	Topr	-20 to 70	°C
Soldering Temperature	Tsol	260*	°C

* Soldering time ≤ 5 s / 2 times.

*Don't touch flux soldering and white Gas

Cliff Electronic Components Ltd.

76 Holmethorpe Avenue, Holmethorpe Industrial Estate,

Redhill, Surrey, RH1 2PF, England, UK

Tel: 01737-771375 Fax: 01737-766012 Website: www.cliffuk.co.uk

Electro-Optical Characteristics

Parameter	Symbol	Conditions	MIN.	TYP.	MAX.	Unit
Operating Voltage	V _{cc}	-	2.7	-	5.5	V
Peak Detective Wavelength	λ_p	-	-	660	-	nm
Transfer Speed		NRZ signal	0.1	-	16	Mbps
Transmission Distance		Using APF	0.2	-	20	m
Pulse Width Distortion	Δtw	16Mbps NRZ Signal	-20	-	20	ns
Fiber Coupling Light Input	P _i	*1	-24	-	-14.5	dBm
Dissipation Current	I _{cc}	*2	-	2.5	10	mA
High Level Output Voltage	V _{OH}		2.4	-	-	v
Low Level Output Voltage	V _{OL}		-	-	0.4	v
Rise Time	t _r	*3	-	-	25	ns
Fall Time	t _f	*3	-	-	25	ns
Low → High propagation delay time	t _{PLH}	*3	-	-	100	ns
High → Low propagation delay time	t _{PHL}	*3	-	-	100	ns
Jitter	Δtj	*3	-	1.5	10	ns

Mechanical Electro-Optical Characteristics (Jack)

Parameter	Symbol	Conditions	MIN.	TYP.	MAX.	Unit
Insertion and withdrawal force	F _p	*a	5	-	35	N
Contact resistance	R _{con}	*b	-	-	30	m Ω
Isolation resistance	R _{iso}	D.C.500V, 1min	100	-	-	M Ω

*a Using JIS C6560 standard plug (ϕ 3.5) for test.

*b It measures at 100 mA or less 1000 Hz at the condition of inserting JIS C6560 plug .

FCR684204R light transmitting unit satisfies EIAJ CP-1301A digital audio interface standard.

Cliff Electronic Components Ltd.

76 Holmethorpe Avenue, Holmethorpe Industrial Estate,

Redhill, Surrey, RH1 2PF, England, UK

Tel: 01737-771375 Fax: 01737-766012 Website: www.cliffuk.co.uk**Reliability Test Items**

No.	Item	Test Condition	Test Hour/Cycle	Samples	Number (n) Failure (c)
1	Soldering Heat	260°C±5°C	5 sec./2times	22	n=22, c=0
2	High temp. & Hum. storage	Ta=40°C, 90%RH	500	22	n=22, c=0
3	High temp. storage	Ta=80°C	500	22	n=22, c=0
4	Low Temp. storage	Ta=-30°C	500	22	n=22, c=0
5	Temp. cycling	-30°C ~ 80°C (30min) (5min) (30min)	20	22	n=22, c=0
6	High Temp. Operation life	Ta=60°C, Vcc=5V ON	500	22	n=22, c=0
7	Repeated operation	500 times	Coupling force < 3.5kg 0.4kg<Detaching force <3.5kg	22	n=22, c=0
8	Terminal Strength(tension)	Weight: 500 g 30 sec./each terminal		22	n=22, c=0
9	Terminal Strength(bending)	Weight: 500 g 2 times/each terminal		22	n=22, c=0
10	Mechanical Shock	Acceleration: 1000m/s ² Pulse width: 6 ms 3 times/ X,Y,Z direction		22	n=22, c=0
11	Vibration	Frequency range: 10~55 Hz /sweep 1 min Overallamplitude:1.5 mm 2H./X,Y,Z direction		22	n=22, c=0

I_{cc} (dissipation current): CURRENT ATTENUATE DIFFERENCE < 20%T_{PLH} (propagation L → H delay time): DELAY TIME DIFFERENCE < 20%T_{PHL} (propagation H → L delay time): DELAY TIME DIFFERENCE < 20%T_r (rise time): TIME DIFFERENCE < 20%T_f (fall time): TIME DIFFERENCE < 20%

Cliff Electronic Components Ltd.

76 Holmethorpe Avenue, Holmethorpe Industrial Estate,
Redhill, Surrey, RH1 2PF, England, UK
Tel: 01737-771375 Fax: 01737-766012 Website: www.cliffuk.co.uk

Measuring Method

*1 Measuring method of optical input coupling fiber

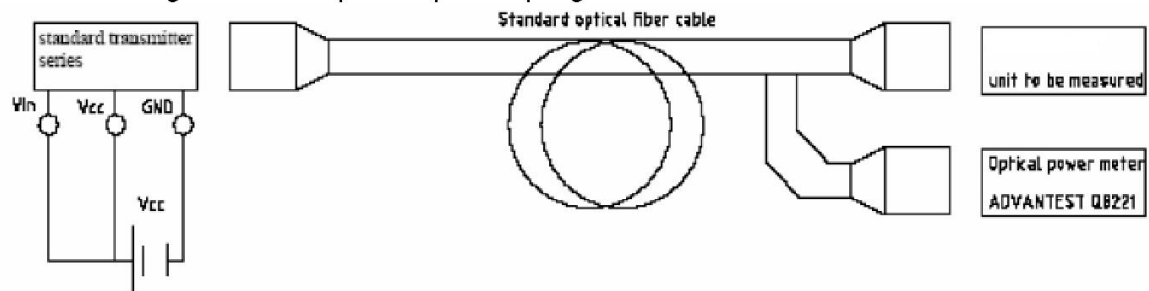

*2 Current dissipation measuring method

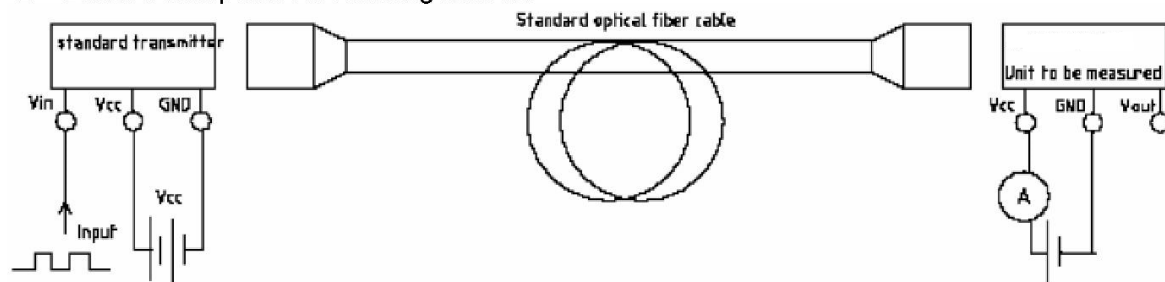

*3 Pulse response and jitter measuring method

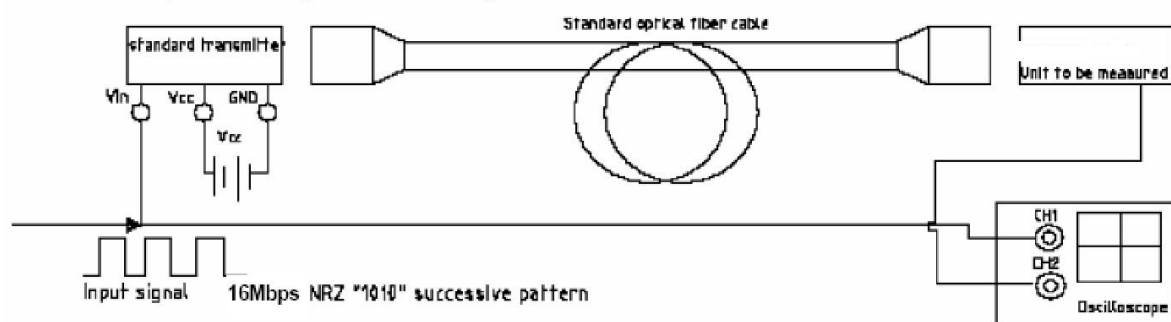

Cliff Electronic Components Ltd.

76 Holmethorpe Avenue, Holmethorpe Industrial Estate,

Redhill, Surrey, RH1 2PF, England, UK

Tel: 01737-771375 Fax: 01737-766012 Website: www.cliffuk.co.uk

PCB Layout For Electrical Circuit

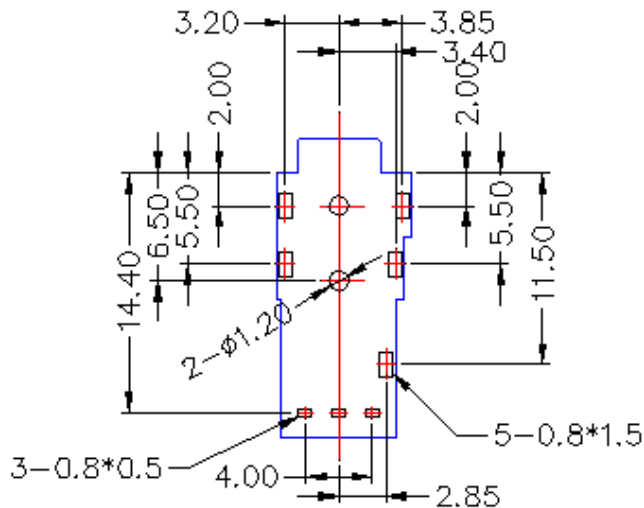

基板參考圖(公差±0.3)

PCB LAYOUT(Tol.±0.3)

(BOTTOM VIEW)

Notes:

1. Unit: mm
2. Unspecified tolerance: $\pm 0.3\text{mm}$
3. Substrate Thickness: 1.6mm

Precautions for Using Method

1. Connect a by-pass capacitor (0.1 μF) close to FCR684204R within 7mm of the unit lead frame.
2. Connect a by-pass capacitor (30pF) between GND and Vout avoid loading effect.
3. Take proper electrostatic-discharge (ESD) precautions while handling these devices. These devices are sensitive to ESD.

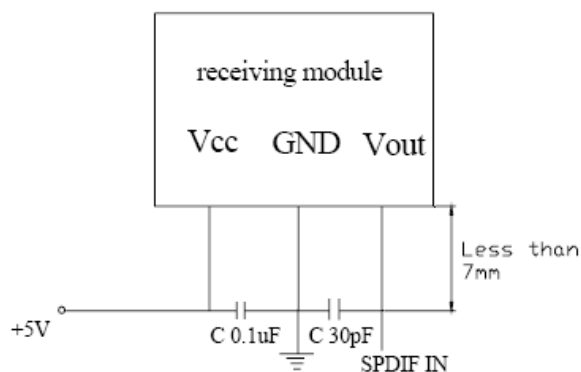

Cliff Electronic Components Ltd.

76 Holmethorpe Avenue, Holmethorpe Industrial Estate,

Redhill, Surrey, RH1 2PF, England, UK

Tel: 01737-771375 Fax: 01737-766012 Website: www.cliffuk.co.uk

Material Description

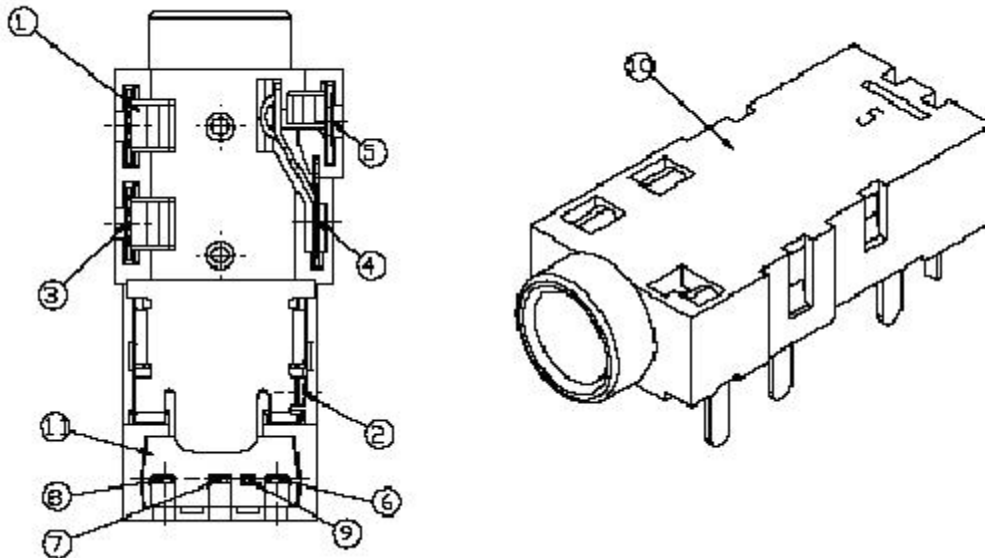

ITEM	NAME	MATERIAL	FINISH	NOTE
1	Jack Terminal	PBS	Au	
2	Jack Terminal	PBS	Au	
3	Jack Terminal	PBS	Au	
4	Jack Terminal	Be-Cu	Au	
5	Jack Terminal	PBS	Au	
6	Vout	PBS	Tin	
7	GND	PBS	Tin	
8	Vcc	PBS	Tin	
9	internal connection	PBS	Tin	
10	Jack Body	PA-9T		UL94V-0
11	Cover	PA-9T		UL94V-0