

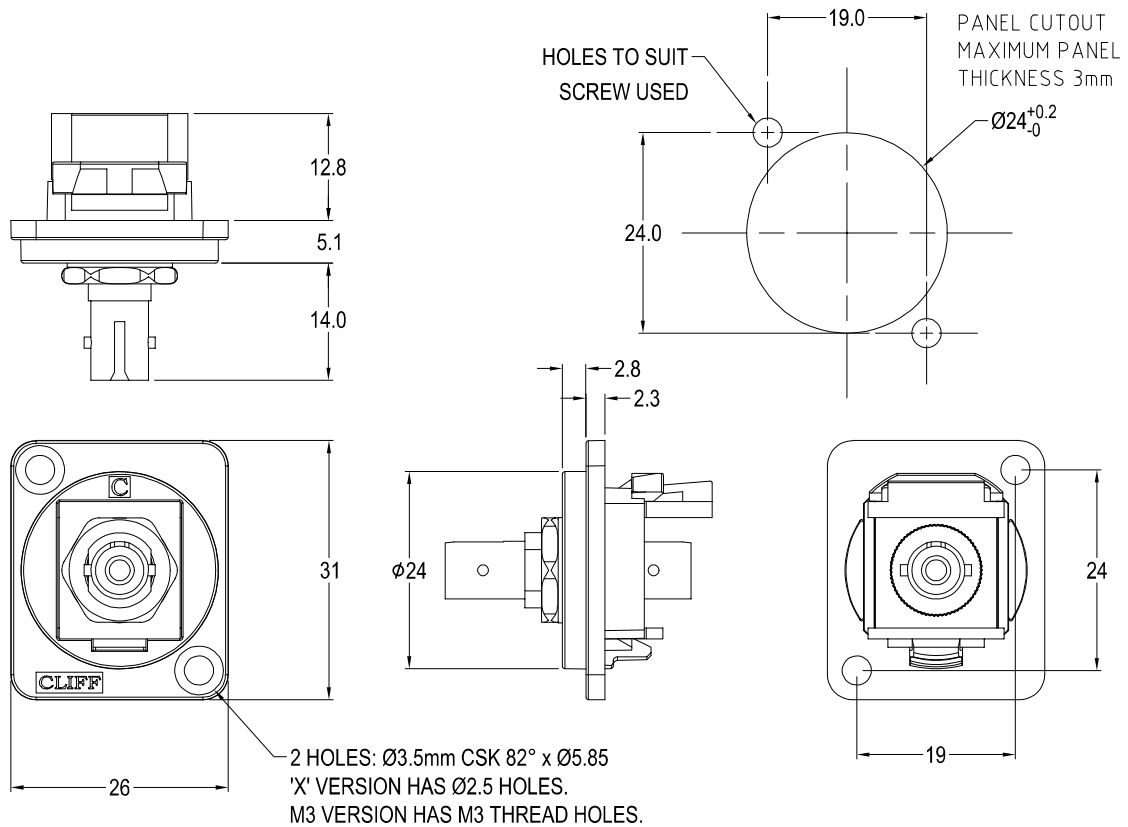

ST FIBRE FEEDTHROUGH CONNECTOR



Feedthrough Features

- Fits standard XLR $\varnothing 24\text{mm}$ cutout.
- No soldering or punch termination. Use standard cable for each connector style.
- Front or rear mounted.
- Low rear profile

General:

Please note: Functionality is affected by cable quality, length and cable wiring configuration.

Material:

1. Insert: ABS UL94 HB
2. Plastic Frame: Polyamide UL94 V-2
3. Metal Frame: Diecast, Black or Nickel plated
4. ST Contacts: Nickel Plated

VARIANTS

Part No.

CP30218	ST Fibre Black plastic frame, CSK holes
CP30218M	ST Fibre Nickel plated metal frame, CSK holes
CP30218M3	ST Fibre Nickel plated metal frame, M3 holes
CP30218MB	ST Fibre Black metal frame, CSK holes
CP30218M3B	ST Fibre Black metal frame, M3 holes
CP30218X	ST Fibre Black plastic frame, PLAIN holes