

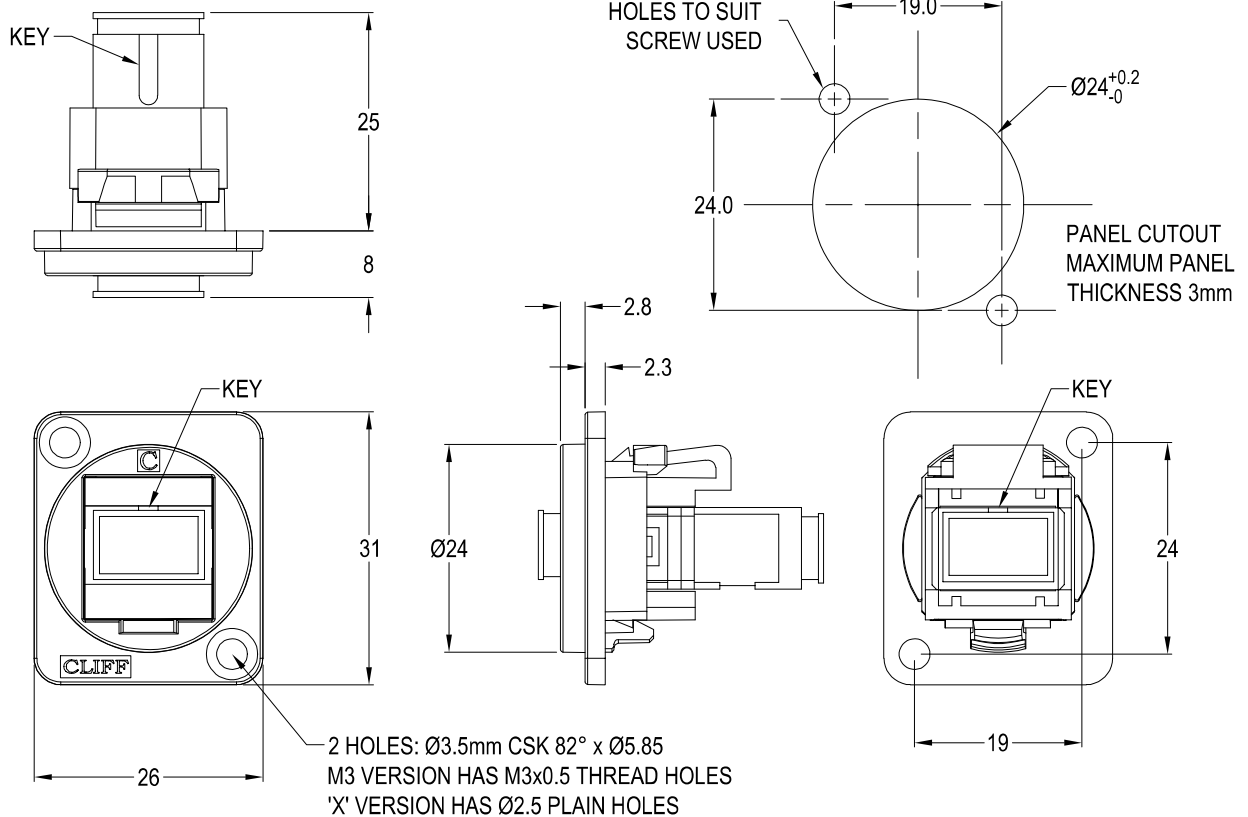

SC SIMPLEX MM FEEDTHROUGH CONNECTOR



Feedthrough Features

- Fits standard XLR Ø24mm cutout.
- No soldering or punch termination. Use standard cable for each connector style.
- Front or rear mounted.
- Low rear profile

General:

Please note: Functionality is affected by cable quality, length and cable wiring configuration.

VARIANTS

Part No.

CP30216	SC Simplex MM Black plastic frame, CSK holes
CP30216M	SC Simplex MM Nickel plated metal frame, CSK holes
CP30216M3	SC Simplex MM Nickel plated metal frame, M3 holes
CP30216MB	SC Simplex MM Black metal frame, CSK holes
CP30216M3B	SC Simplex MM Black metal frame, M3 holes
CP30216X	SC Simplex MM Black plastic frame, PLAIN holes

Material:

1. Coupler Body: ABS UL94 V-2 - Beige
2. Plastic Frame: PA66 UL94 V-2 - Black
3. Metal Frame: Diecast, Black or Nickel plated
4. Sleeve: Ceramic
5. Dust Cover: ABS - Black
6. Insert: ABS UL94 V-2 - Black

Notes:

1. Insertion Loss: ≤0.3dB
2. Dust caps may vary