

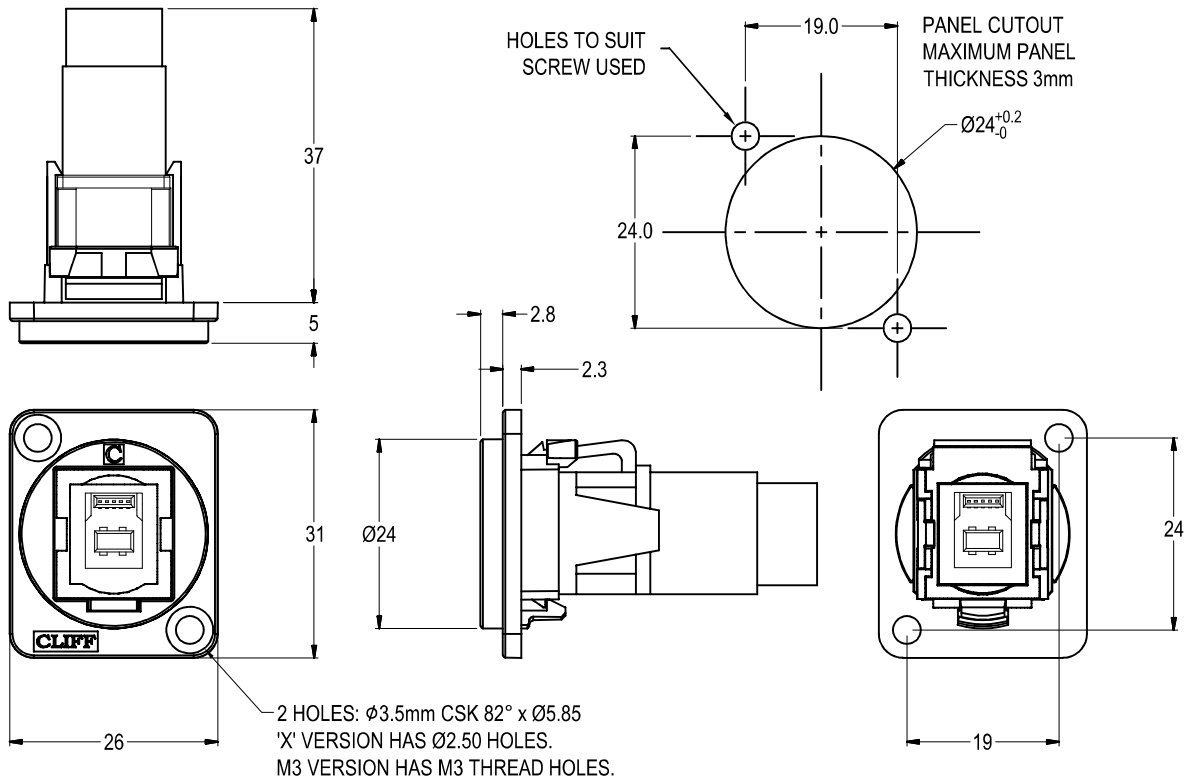

# USB3.0 B-B FEEDTHROUGH CONNECTOR

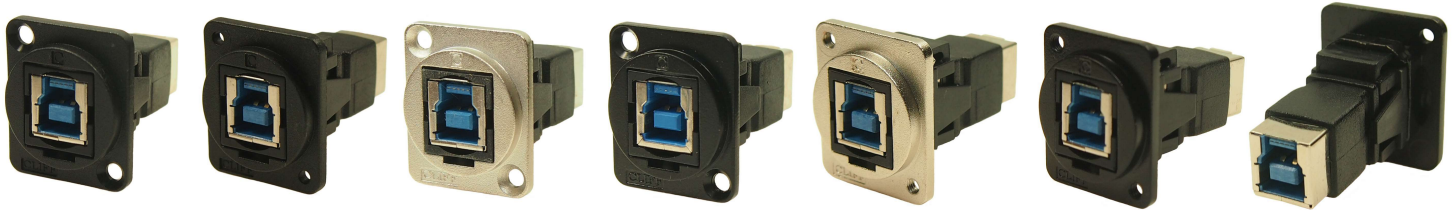

### Feedthrough Features

- Fits standard XLR Ø24mm cutout.
- No soldering or punch termination. Use standard cable for each connector style.
- Front or rear mounted.
- Low rear profile

### General:

Please note: Functionality is affected by cable quality, length and cable wiring configuration.

### VARIANTS

#### Part No.

- CP30204N** USB3.0 B-B Black plastic frame, CSK holes
- CP30204NM** USB3.0 B-B Nickel plated metal frame, CSK holes
- CP30204NM3** USB3.0 B-B Nickel plated metal frame, M3 holes
- CP30204NMB** USB3.0 B-B Black metal frame, CSK holes
- CP30204NM3B** USB3.0 B-B Black metal frame, M3 holes
- CP30204NX** USB3.0 B-B Black plastic frame, PLAIN holes

### Material:

1. Insert: ABS
2. Plastic Frame: Polyamide UL94 V2
3. Metal Frame: Diecast, Black or Nickel plated
4. Shell: Nickel plated steel
5. Contacts: Gold Plated

### Notes:

1. Voltage rating: 30V AC
2. Current rating: 1.8 A max
3. Contact resistance: 50mΩ max
4. Insulation resistance: 20MΩ min
5. Dielectric withstanding voltage: 500V AC
6. Operating Temperature: -20°C to 50°C

