

# CLIFF

## SLIM USB2.0 A-B FRONT MOUNTING METAL FRAME FEEDTHROUGH

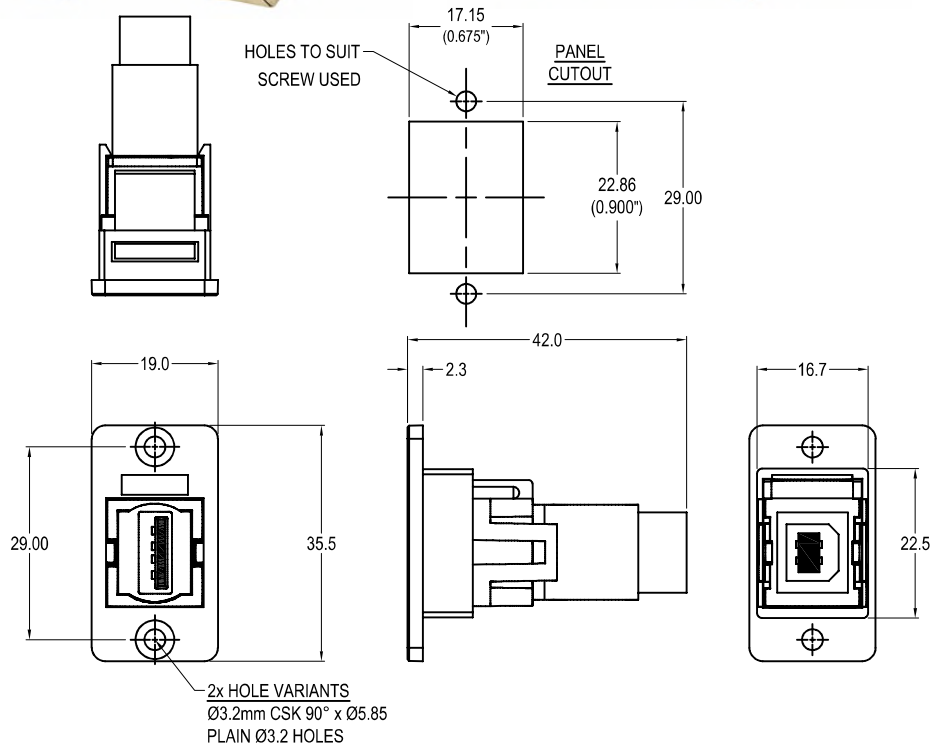

### VARIANTS

Part No.

<b>CP30609NM</b>	SLIM FM USB2.0 A-B Nickel frame, CSK holes
<b>CP30609NMB</b>	SLIM FM USB2.0 A-B Black metal frame, CSK holes
<b>CP30609NMX1</b>	SLIM FM USB2.0 A-B Nickel frame, Ø3.2 PLAIN holes
<b>CP30609NMBX1</b>	SLIM FM USB2.0 A-B Black metal frame, Ø3.2 PLAIN holes

### Feedthrough Features

- Fits standard rectangular cutout.
- Various hole mounting options.
- No soldering or punch termination. Use standard cable for each connector style.
- Low rear profile.

### General:

Please note: Functionality is affected by cable quality, length and cable wiring configuration.

### Material:

1. Insert: ABS
2. Frame: Diecast, Nickel or Black plated
3. Inner Overmouldings: PE + PVC
4. Shell: Nickel plated steel
5. Contacts: Gold Plated

### Notes:

1. Voltage rating: 30V AC
2. Current rating: 1.5 A max
3. Contact resistance: 50mΩ max
4. Insulation resistance: 20MΩ min
5. Dielectric withstanding voltage: 500V AC
6. Operating Temperature: -20°C to 50°C