

CLIFF

CAT5e RJ45 RIGHT ANGLE FEEDTHROUGH CONNECTOR (RAFT)

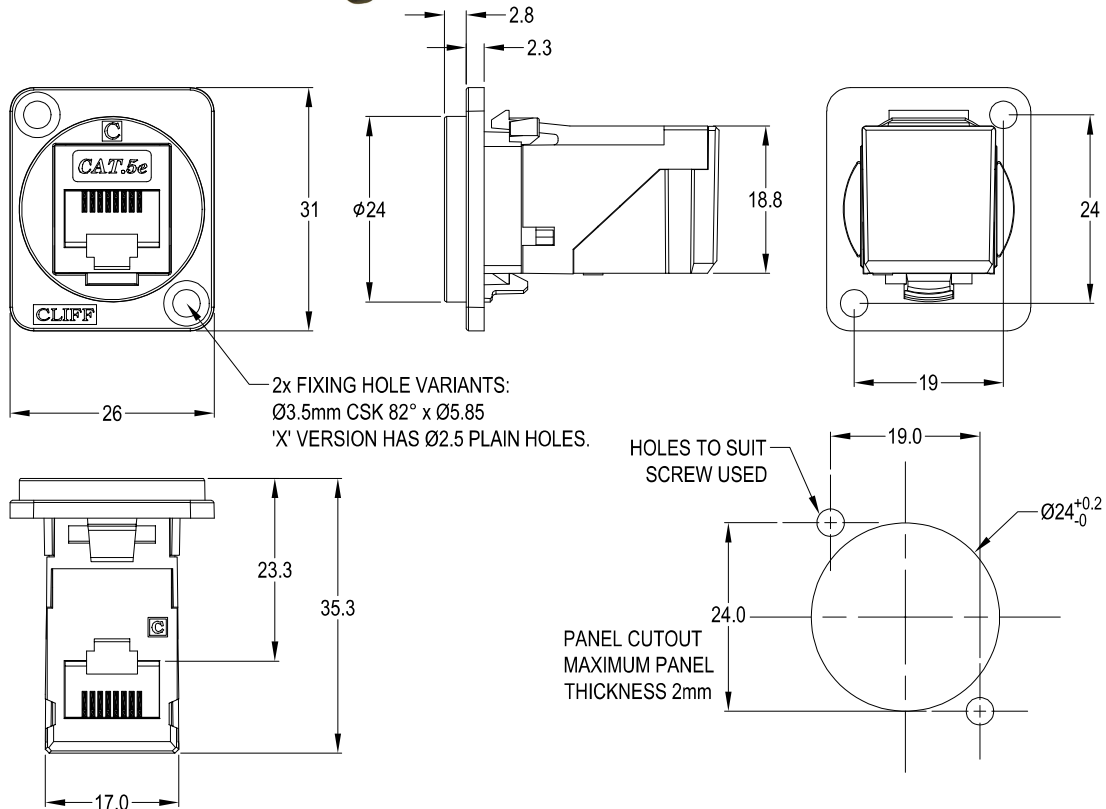

VARIANTS

Part No.

CP30251 RAFT Cat5e RJ45 Black plastic frame, CSK holes

CP30251X RAFT Cat5e RJ45 Black plastic frame, 2.5mm PLAIN holes

Feedthrough Features

- Fits standard XLR Ø24mm cutout.
- No soldering or punch termination. Use standard cable for each connector style.
- Front or rear mounted.
- Low rear profile
- 90° or right angle rear cable entry.

General:

Please note: Functionality is affected by cable quality, length and cable wiring configuration.

Material:

1. RJ45 In-Line Coupler: ABS UL94-V2
2. RJ45 In-Line Coupler Contact: Phosphor Bronze, gold plating.
3. PCB: FR4
4. Frame: Polyamide UL94-V2

Performance:

1. T568A & T568B wiring.
2. Meet ISO/IEC 11801 and EN50173
3. Meet ANSI/TIA/EIA 568B.2
4. Rating 125VAC RMS 1.5A
5. Operating Temperatures: Min -10°C Max +60°C